

Building Sketch (Page - 1)

| | | | | |
|-------------------------------------|--------|--------|--------|-------------------------|
| Borrower | | | | |
| Property Address 1620 University Dr | | | | |
| City | Durham | County | Durham | State NC Zip Code 27707 |
| Lender/Client | | | | |

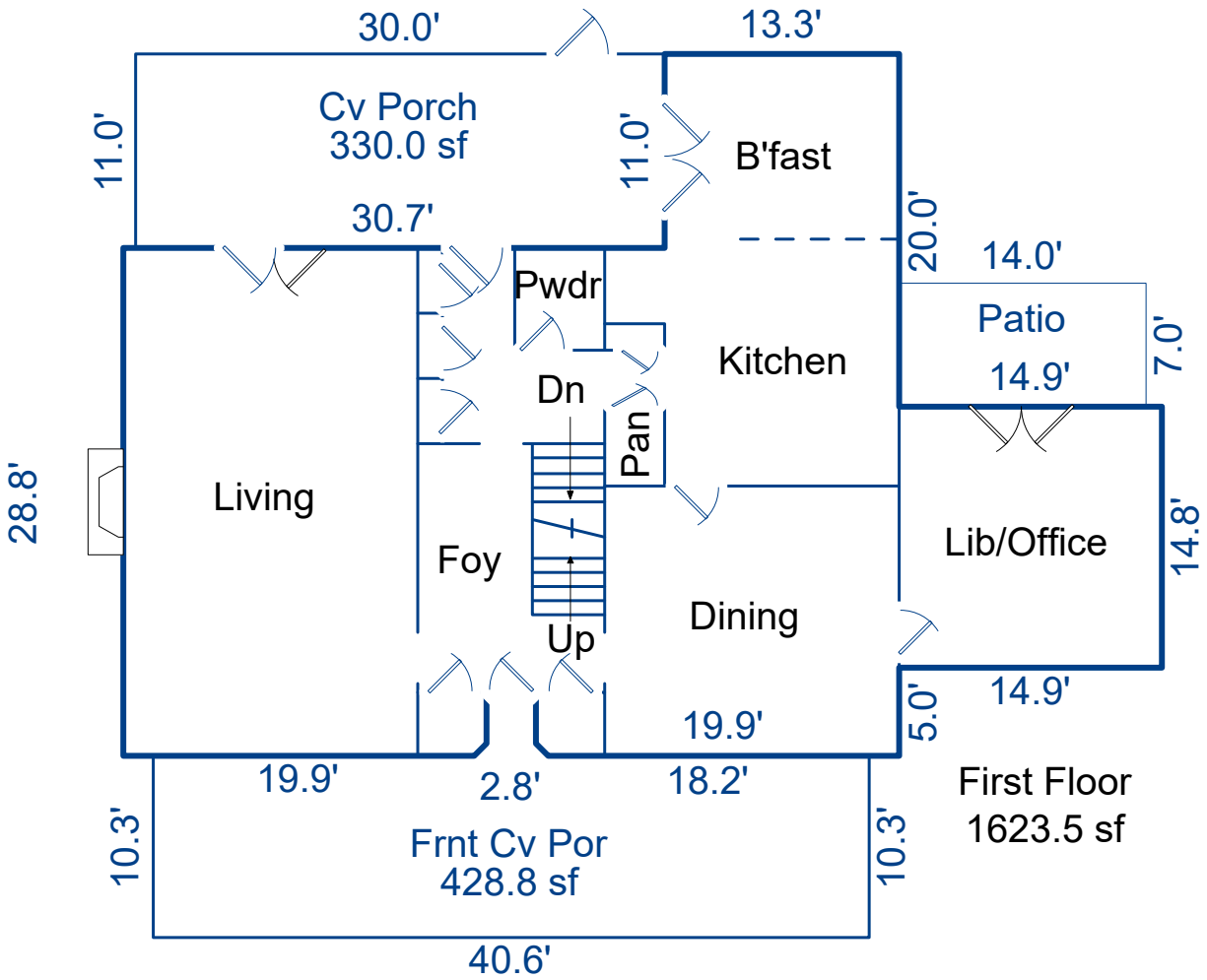

Sketch by Apex Sketch

| AREA CALCULATIONS SUMMARY | | | | | | AREA CALCULATIONS BREAKDOWN | | | | |
|---------------------------|-------------|--------|----------|-----------|------------|-----------------------------|--------|----------|-----------|-------|
| Code | Description | Factor | Net Size | Perimeter | Net Totals | Name | Base x | Height x | Width = | Area |
| GLA1 | First Floor | 1.0 | 1623.5 | 203.8 | 1623.5 | First Floor | | 14.9 x | 14.8 = | 220.5 |
| P/P | Cv Porch | 1.0 | 330.0 | 82.0 | | | 0.5 x | 1.0 x | 0.5 = | 0.2 |
| | Patio | 1.0 | 98.0 | 42.0 | | | 0.5 x | 1.0 x | 0.5 = | 0.2 |
| | Frnt Cv Por | 1.0 | 428.8 | 108.2 | 856.8 | | | 25.2 x | 4.2 = | 105.8 |
| | | | | | | | | 2.9 x | 0.7 = | 2.0 |
| | | | | | | | | 2.9 x | 0.7 = | 2.0 |
| | | | | | | | | 28.8 x | 19.9 = | 573.1 |
| | | | | | | | | 28.8 x | 19.9 = | 573.1 |
| | | | | | | | | 13.3 x | 11.0 = | 146.3 |
| | Net LIVABLE | | | (rounded) | 1,623 | 9 total items | | | (rounded) | 1,623 |

© Starcap Marketing, LLC. dba Apex Software

Building Sketch (Page - 2)

| | | | | |
|-------------------------------------|--------|--------|--------|-------------------------|
| Borrower | | | | |
| Property Address 1620 University Dr | | | | |
| City | Durham | County | Durham | State NC Zip Code 27707 |
| Lender/Client | | | | |

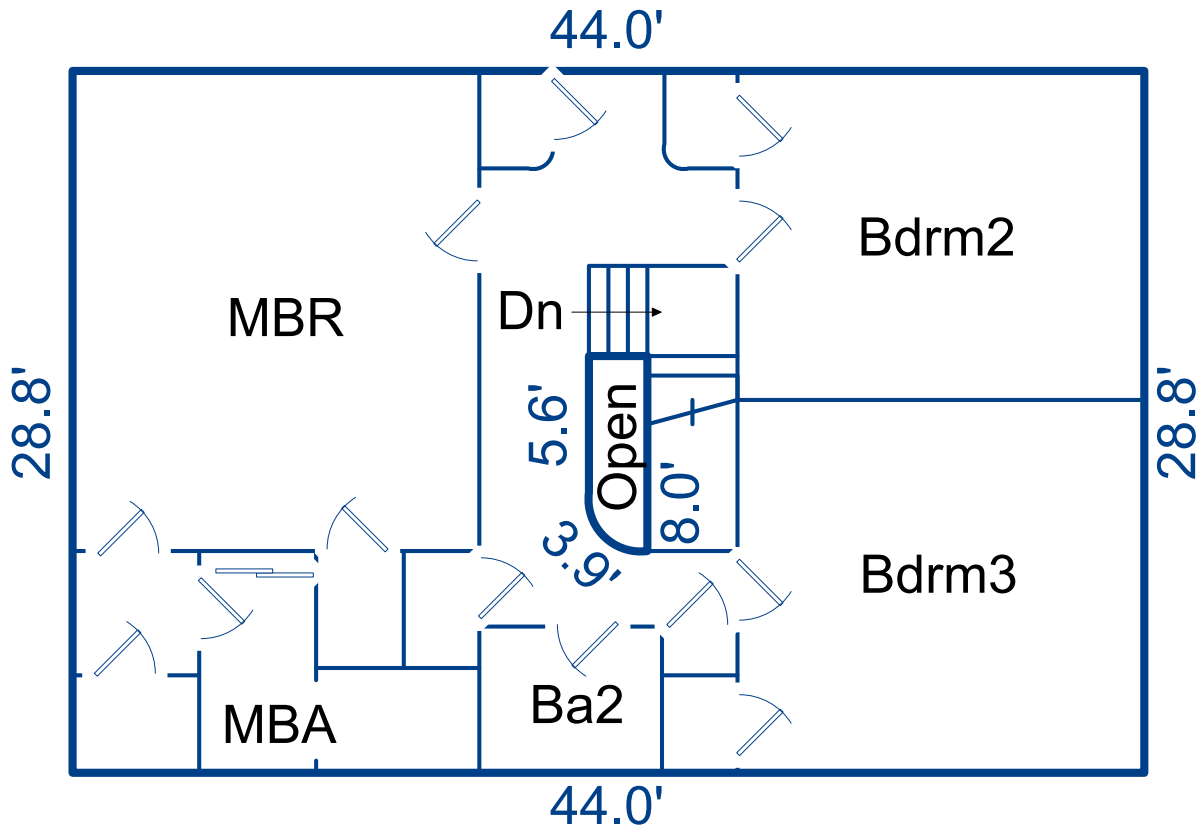

Second Floor
1267.2 sf

Sketch by Apex Sketch

| AREA CALCULATIONS SUMMARY | | | | | | AREA CALCULATIONS BREAKDOWN | | | | |
|---------------------------|--------------|--------|----------|-----------|------------|-----------------------------|--------|----------|-----------|--------|
| Code | Description | Factor | Net Size | Perimeter | Net Totals | Name | Base x | Height x | Width = | Area |
| GLA2 | Second Floor | 1.0 | 1267.2 | 145.6 | | Second Floor | 44.0 x | 28.8 x | | 1267.2 |
| | Second Floor | -1.0 | -18.3 | 19.9 | 1248.9 | | | 5.6 x | 2.4 = | 13.4 |
| | | | | | | | 0.5 x | 3.4 x | 1.7 = | 2.9 |
| | | | | | | | Curve | 3.4 @ | 105° = | 2.0 |
| | Net LIVABLE | | | (rounded) | 1,249 | 4 total items | | | (rounded) | 1,286 |

Building Sketch (Page - 3)

| | | | | |
|-------------------------------------|--------|--------|--------|-------------------------|
| Borrower | | | | |
| Property Address 1620 University Dr | | | | |
| City | Durham | County | Durham | State NC Zip Code 27707 |
| Lender/Client | | | | |

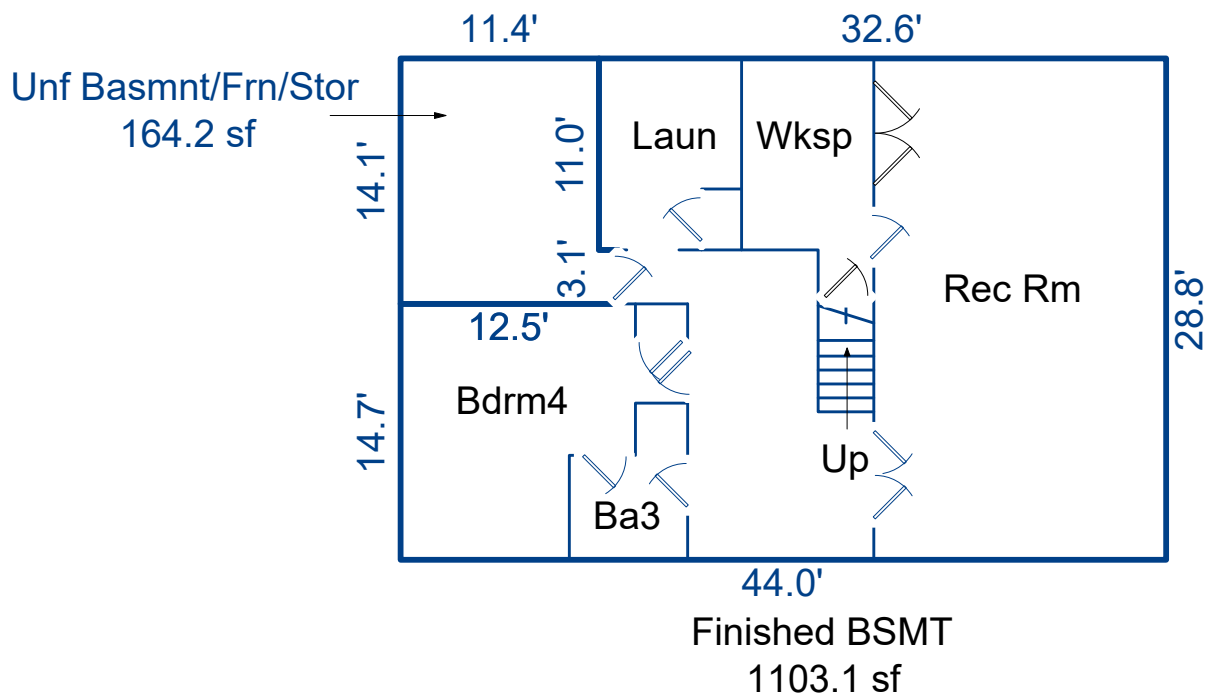

Sketch by Apex Sketch

| AREA CALCULATIONS SUMMARY | | | | | | AREA CALCULATIONS BREAKDOWN | | | | |
|---------------------------|-----------------|--------|----------|-----------|------------|-----------------------------|--------|----------|---------|------|
| Code | Description | Factor | Net Size | Perimeter | Net Totals | Name | Base x | Height x | Width = | Area |
| BSMT | Finished BSMT | 1.0 | 1103.1 | 147.8 | | | | | | |
| | Unf Basmnt/Frn/ | 1.0 | 164.2 | 53.2 | 1267.2 | | | | | |
| | | | | | | 0 total items (rounded) 0 | | | | |

Building Sketch (Page - 4)

| | | | | |
|-------------------------------------|--------|--------|--------|-------------------------|
| Borrower | | | | |
| Property Address 1620 University Dr | | | | |
| City | Durham | County | Durham | State NC Zip Code 27707 |
| Lender/Client | | | | |

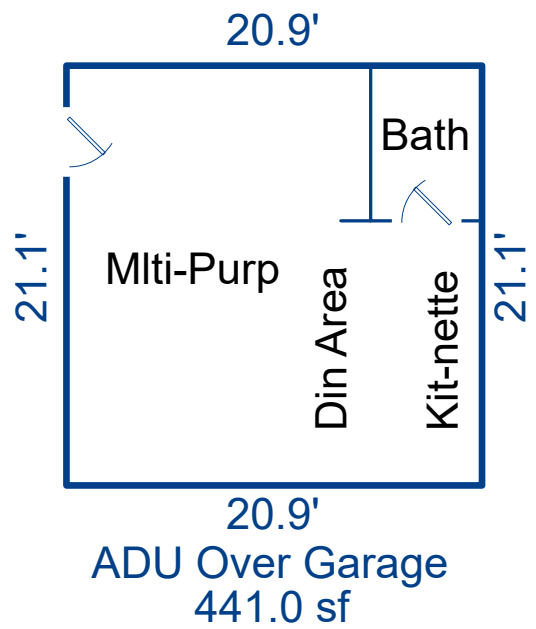
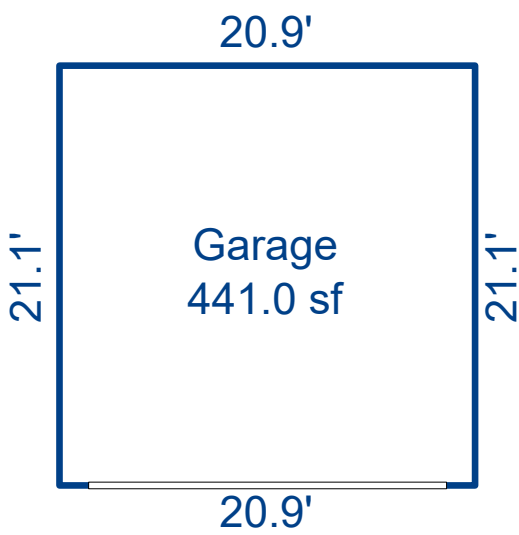

Sketch by Apex Sketch

| AREA CALCULATIONS SUMMARY | | | | | | AREA CALCULATIONS BREAKDOWN | | | | |
|---------------------------|----------------|--------|-----------|-----------|------------|-----------------------------|--------|----------|-----------|-------|
| Code | Description | Factor | Net Size | Perimeter | Net Totals | Name | Base x | Height x | Width = | Area |
| GBA2 | ADU Over Garag | 1.0 | 441.0 | 84.0 | 441.0 | ADU Over Garage | | 21.1 x | 20.9 = | 441.0 |
| GAR | Garage | 1.0 | 441.0 | 84.0 | 441.0 | | | | | |
| Net BUILDING | | | (rounded) | | 441 | 1 total items | | | (rounded) | 441 |

© Starcap Marketing, LLC. dba Apex Software