

### Building Sketch (Page - 1)

Borrower				
Property Address	1025 Islip Pl			
City	Durham	County	Durham	State NC Zip Code 27703
Lender/Client				

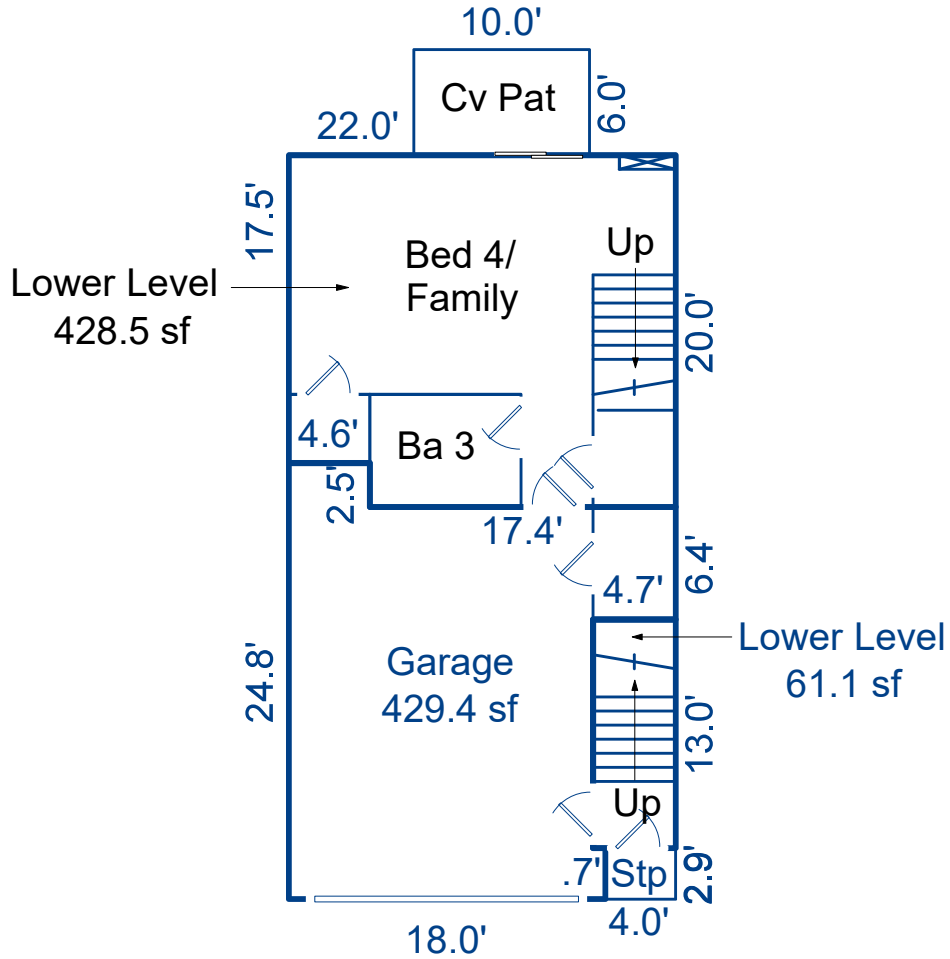

Sketch by Apex Sketch

AREA CALCULATIONS SUMMARY					AREA CALCULATIONS BREAKDOWN					
Code	Description	Factor	Net Size	Perimeter	Net Totals	Name	Base x	Height x	Width =	Area
GLA1	Lower Level	1.0	61.1	35.4		Lower Level	13.0 x	4.7	=	61.1
	Lower Level	1.0	428.5	84.0	489.6	Lower Level	20.0 x	17.4	=	348.0
GAR	Garage	1.0	429.4	95.0	429.4		17.5 x	4.6	=	80.5
P/P	Covered Patio	1.0	60.0	32.0						
	Stp	1.0	11.6	13.8	71.6					
	Net LIVABLE		(rounded)		490	3 total items			(rounded)	490

### Building Sketch (Page - 2)

Borrower				
Property Address	1025 Islip Pl			
City	Durham	County	Durham	State NC Zip Code 27703
Lender/Client				

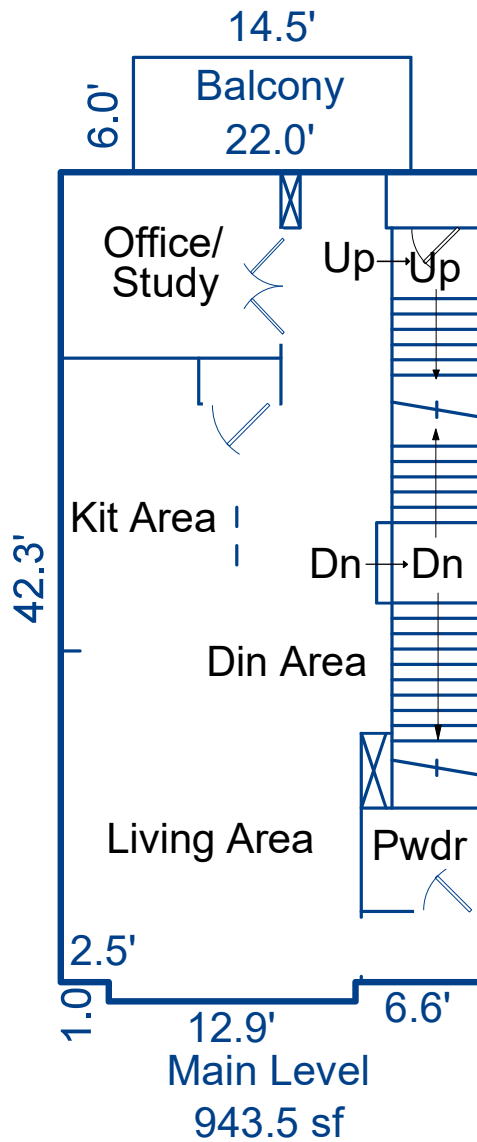

Sketch by Apex Sketch

AREA CALCULATIONS SUMMARY						AREA CALCULATIONS BREAKDOWN				
Code	Description	Factor	Net Size	Perimeter	Net Totals	Name	Base x	Height x	Width =	Area
GLA2	Main Level	1.0	943.5	130.6	943.5	Main Level	12.9 x	1.0 x	=	12.9
P/P	Balcony	1.0	87.0	41.0	87.0		42.3 x	22.0 x	=	930.6
Net LIVABLE			(rounded)		944	2 total items	(rounded)			944

© Starcap Marketing, LLC. dba Apex Software

**Building Sketch (Page - 3)**

Borrower				
Property Address	1025 Islip Pl			
City	Durham	County	Durham	State NC Zip Code 27703
Lender/Client				

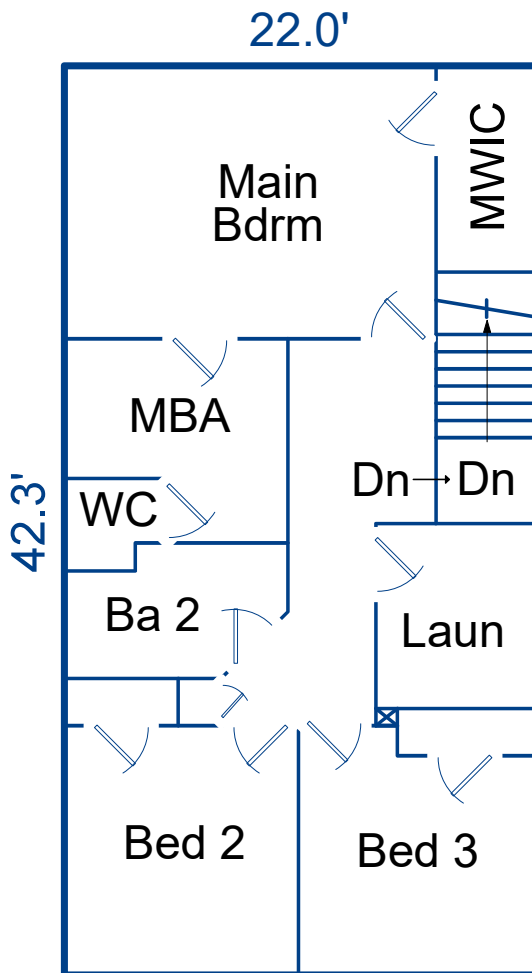

**Upper Level**  
**930.6 sf**

Sketch by Apex Sketch

AREA CALCULATIONS SUMMARY						AREA CALCULATIONS BREAKDOWN				
Code	Description	Factor	Net Size	Perimeter	Net Totals	Name	Base x	Height x	Width =	Area
GLA3	Upper Level	1.0	930.6	128.6	930.6	Upper Level		42.3 x	22.0 =	930.6
	Net LIVABLE		(rounded)		931	1 total items			(rounded)	931